

EXTERIOR ELEVATION

MAX. FRAME SIZE (IN.)	IMPACT
38.22" x 98.59	NO
APPLICABLE FOR SINGLE UNITS ONLY	

**FRAME ANCHOR REQUIREMENTS TABLE**

FRAME/CLIP TO OPENING FASTENER TYPE	MINIMUM EMBED	MINIMUM EDGE DIST.
#10 PFH screws into frame and wood substrate	1-1/4"	See pg. 2
#8 PFH Zinc treated screws into clip and wood substrate at an angle	1-1/2"	—
#8 PFH Zinc treated screws into clip and frame	FULL	See pg. 2

**Installation Method**

Installation Clips	Screws thru the Frame
Sides = 19 3/4" from corners & on center Head = 18 3/4" from corners Sill = Refer to screw installation	Sides = #10 PFH screws spaced 14" from corners and on center. Head = #10 PFH screws spaced 19" from corners Sill = #10 PFH screws spaced 4" from corners and one in the center.

GENERAL NOTES

1. These units have been tested, analyzed, Hallmark certified, and FBC approved.
2. Bucking, openings, and bucking fasteners must be properly designed and installed to transfer wind loads to the structure. The unit was tested with 1/2" rough opening gap.
3. These units were tested with ponderosa pine bucks, Florida building code requires preservative treated southern pine bucks.
4. All hardware and fasteners shall be in accordance with these drawings and may not vary unless specifically mentioned on the drawings.
5. These units have been tested in accordance with and meet the requirements of the Florida Building Code.
6. Impact shutters are required only with non-impact units.
7. All anchors shall be installed as specified on these drawings. Specified embedment base material shall be beyond wall finish or stucco.
8. Testing of one wood species covers all other species with an equal or higher modulus of elasticity and modulus of rupture.
9. Testing of primed covers testing of clad as long as cladding is not structural (extruded), or wraps around the gasket.
10. Testing of windows and doors with a given width and thickness of solid stiles and rails, covers products with wider and thicker solid stiles and rails provided that construction details are consistent.
11. Any fixed geometric shape that fits within the tested/approved size for a particular product type is qualified by the rectangular shape(s) provided that the frame, sash, lpanels, components, and construction remain the same.
12. All fixed shaped units must fit inscribed into the allowable rectangular units and be governed by allowable design pressure or the respective rectangular unit.
13. Shims need to be located a maximum of 4" from each corner and a maximum of 4" from each anchor location.
14. Plywood was used during testing to simulate the finished exterior of the structure. Actual finished exteriors will vary.

**KOLBE** 1323 South 11th Ave.  
Wausau, WI 54401  
715-842-5666  
■ WINDOWS & DOORS ■

**Ultra Series Operating  
Outswing Door**

FL# 12508	R&D No. 14069
Revision	Drawn By: KSS
A SES 12/19/20	Date: 10/1/2015
B	Sheet: 1 of 2
C	Drawing No. 14069

## Installation Clip Installation

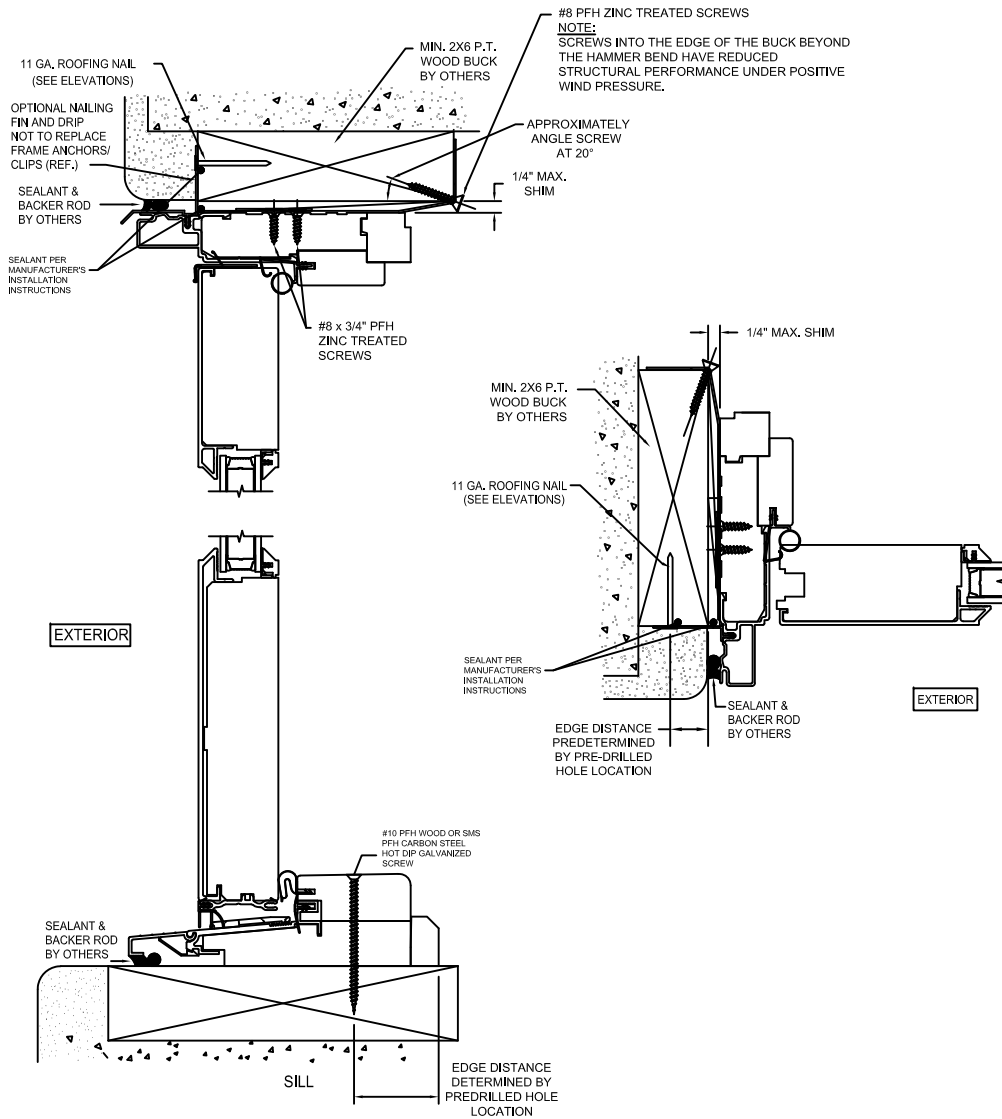

## Screw Installation

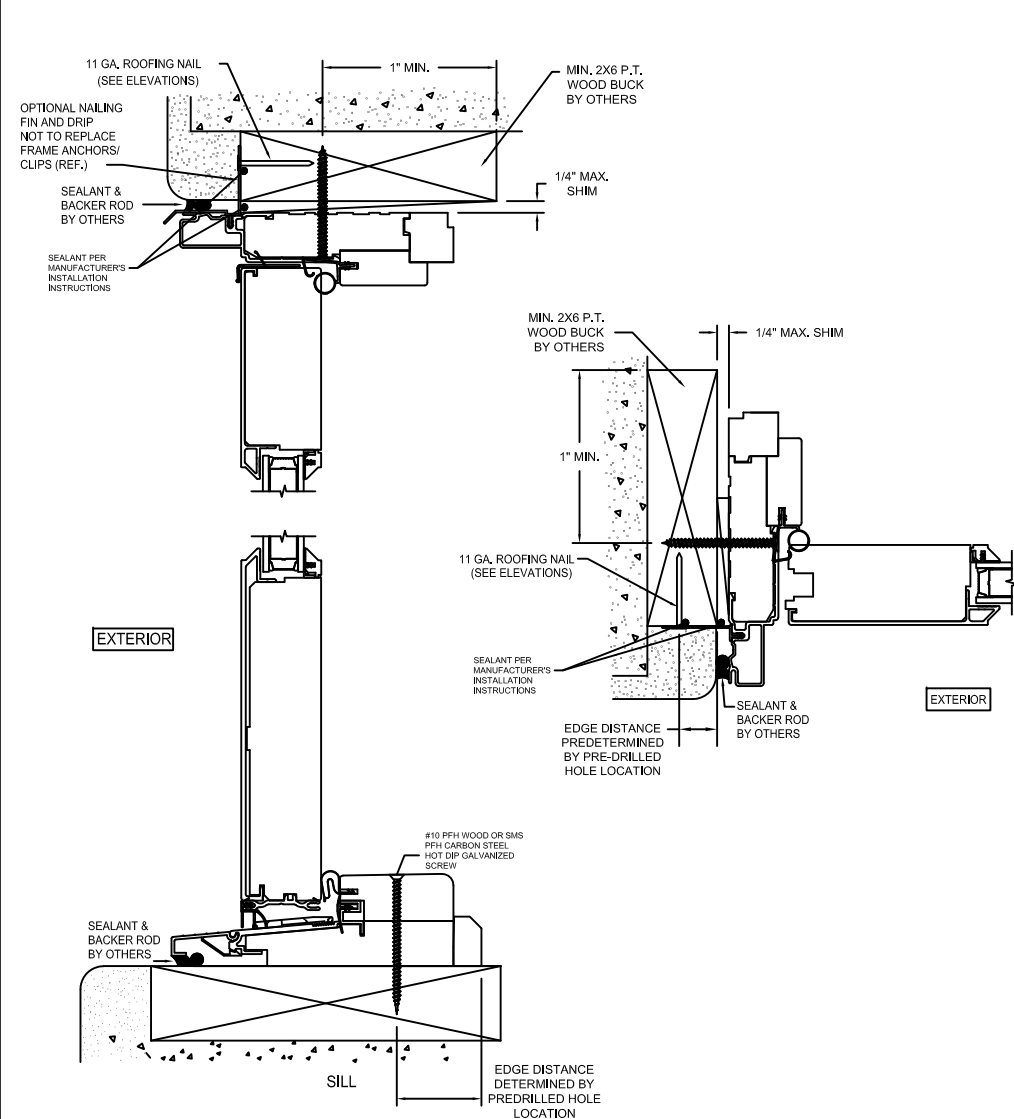

### GENERAL NOTES

1. These units have been tested, analyzed, Hallmark certified, and FBC approved.
2. Bucking, openings, and bucking fasteners must be properly designed and installed to transfer wind loads to the structure. The unit was tested with 1/2" rough opening gap.
3. These units were tested with ponderosa pine bucks, Florida building code requires preservative treated southern pine bucks.
4. All hardware and fasteners shall be in accordance with these drawings and may not vary unless specifically mentioned on the drawings.
5. These units have been tested in accordance with and meet the requirements of the Florida Building Code.
6. Impact shutters are required only with non-impact units.
7. All anchors shall be installed as specified on these drawings. Specified embedment base material shall be beyond wall finish or stucco.
8. Testing of one wood species covers all other species with an equal or higher modulus of elasticity and modulus of rupture.
9. Testing of primed covers testing of clad as long as cladding is not structural (extruded), or wraps around the gasket.
10. Testing of windows and doors with a given width and thickness of solid stiles and rails, covers products with wider and thicker solid stiles and rails provided that construction details are consistent.
11. Any fixed geometric shape that fits within the tested/approved size for a particular product type is qualified by the rectangular shape(s) provided that the frame, sash, panels, components, and construction remain the same.
12. All fixed shaped units must fit inscribed into the allowable rectangular units and be governed by allowable design pressure or the respective rectangular unit.
13. Shims need to be located a maximum of 4" from each corner and a maximum of 4" from each anchor location.
14. Plywood was used during testing to simulate the finished exterior of the structure. Actual finished exteriors will vary.

**KOLBE** 1323 South 11th Ave.  
Wausau, WI 54401  
715-842-5666  
■ WINDOWS & DOORS ■

### Ultra Series Operating Outswing Door

FL# 12508	R&D No. 14069
Revision	Drawn By: MTO
A SES 12/19/20	Date: 10/31/19
B	Sheet: 2 of 2
C	Drawing No. 14069A